

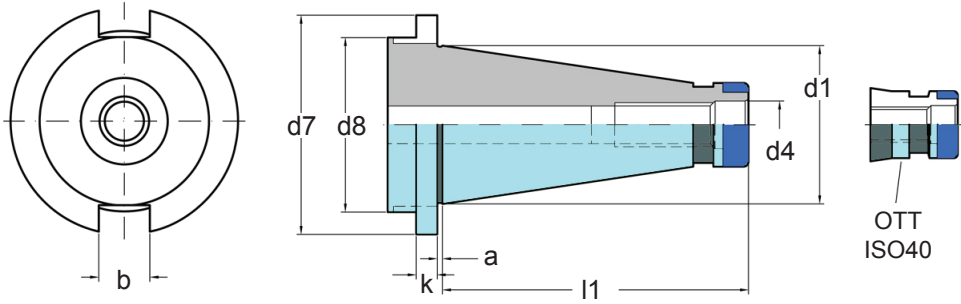

**CONO ISO
DIN/2080**

PROGRAMA

						
PAG. 4	PAG. 4	PAG. 5	PAG. 5	PAG. 6	PAG. 7	PAG. 7
						
PAG. 8	PAG. 9	PAG. 9	PAG. 10	PAG. 10	PAG. 10	PAG. 11
						
PAG. 11	PAG. 12	PAG. 12				



CONO TAPER	FORMA FORM	d1	d4	a	b	l1	d7	k	d8
ISO30	AD	31.75	M12	1.6	16.1	68.4	50	8	32.4
ISO40 *	AD	44.45	M16	1.6	16.1	93.4	63	10	45
ISO50	AD	69.85	M24	3.2	25.7	126.8	97.5	12	70.6

* ISO 40 con regata MAHO-OTT
ISO 40 with MAHO-OTT groove



DIN/2080

Porta pinzas ER tuerca STANDARD
Collet chucks ER STANDARD nut

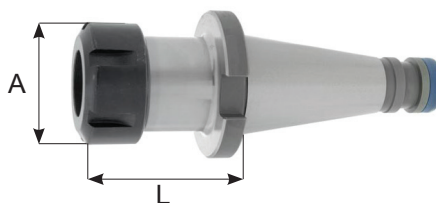

ISO30 / ISO40 / ISO50

REFERENCIA	CAP	RPM	FORMA	L	A
ISO30L50ER25	1 ÷ 20	12.000	AD	50	42
ISO30L50ER32	2 ÷ 22			50	50
ISO30L70ER40	3 ÷ 30			70	63
ISO40L47ER16	1 ÷ 10	12.000	AD	47	32
ISO40L47ER25	1 ÷ 20			47	42
ISO40L49ER32	2 ÷ 22			49	50
ISO40L70ER40	3 ÷ 30			70	63
ISO50L80ER25	1 ÷ 20	12.000	AD	80	42
ISO50L69ER32	2 ÷ 22			69	50
ISO50L63ER40	3 ÷ 30			63	63

DIN/2080

Porta pinzas ER tuerca MINI
Collet chucks ER MINI nut

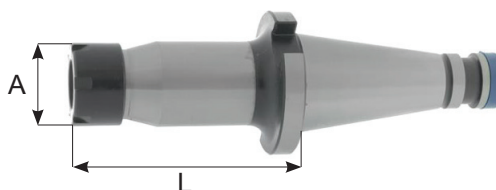

ISO30 / ISO40

REFERENCIA	CAP	RPM	FORMA	L	A
ISO30L100ER8M	1 ÷ 5	8.000	AD	100	12
ISO30L100ER11M	1 ÷ 7			100	16
ISO30L100ER16M	1 ÷ 10			100	22
ISO30L100ER20M	1 ÷ 14			100	28
ISO30L100ER25M	1 ÷ 20			100	35
ISO40L100ER11M	1 ÷ 7	8.000	AD	100	16
ISO40L100ER16M	1 ÷ 10			100	22
ISO40L100ER20M	1 ÷ 14			100	28
ISO40L100ER25M	1 ÷ 20			100	35

DIN/2080

Porta pinzas EOC DIN/6388 B
Collet chucks EOC DIN/6388 B

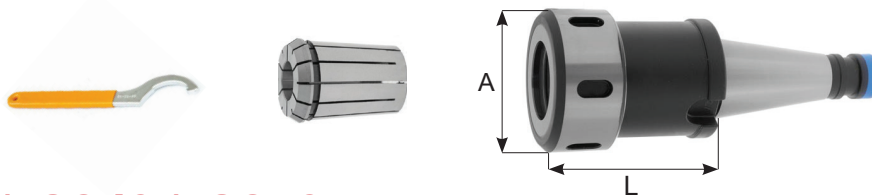

ISO30 / ISO40 / ISO50

REFERENCIA	CAP	RPM	FORMA	L	A
ISO30L50EOC16	2 ÷ 16	12.000	AD	50	43
ISO30L80EOC25	2 ÷ 25			80	60
ISO40L55EOC16	2 ÷ 16	12.000	AD	55	43
ISO40L66EOC25	2 ÷ 25			66	60
ISO40L95EOC32	3 ÷ 32			95	72
ISO50L71EOC25	2 ÷ 25	12.000	AD	71	60
ISO50L73EOC32	3 ÷ 32			73	72

DIN/2080

Porta pinzas gran apriete
Power milling chucks

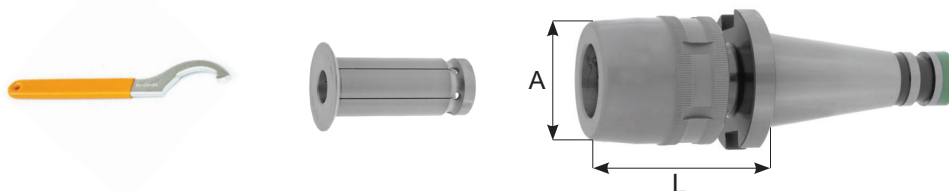

ISO30 / ISO40 / ISO50

REFERENCIA	CAP	RPM	FORMA	L	A
ISO40L78MC32	3 ÷ 32	12.000	AD	78	74
ISO50L85MC32	3 ÷ 32	12.000	AD	85	74



DIN/2080

Porta pinzas hidráulico
Hydraulic Collet chucks

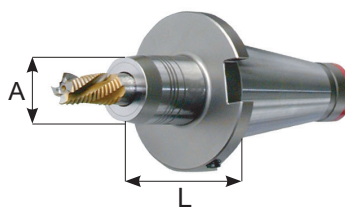
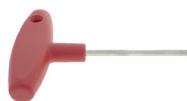

ISO40

REFERENCIA	D	FORMA	L	A
ISO40L49HD6	6	AD	49	26
ISO40L49HD8	8	AD	49	28
ISO40L53HD10	10	AD	53	30
ISO40L58HD12	12	AD	58	32
ISO40L58HD14	14	AD	58	34
ISO40L61HD16	16	AD	61	38
ISO40L61HD18	18	AD	61	40
ISO40L63HD20	20	AD	63	42
ISO40L70LD25	25	AD	70	50
ISO40L75HD32	32	AD	75	60

ISO50

REFERENCIA	D	FORMA	L	A
ISO50L53HD6	6	AD	53	26
ISO50L53HD8	8	AD	53	28
ISO50L57HD10	10	AD	57	30
ISO50L62HD12	12	AD	62	32
ISO50L62HD14	14	AD	62	34
ISO50L65HD16	16	AD	65	38
ISO50L65HD18	18	AD	65	40
ISO50L67HD20	20	AD	67	42
ISO50L72HD25	25	AD	72	50
ISO50L76HD32	32	AD	76	60
ISO50L90LD40	40	AD	90	70
ISO50L115HD50	50	AD	115	78
ISO50L130LD60	60	AD	130	97.5

DIN/2080

Porta brocas con llave de gancho
Drill chucks with hook wrench

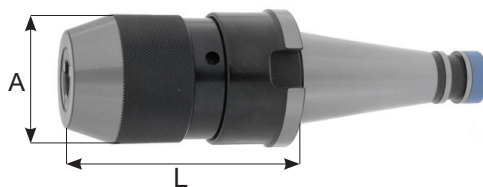

ISO40 / ISO50

REFERENCIA	CAP	RPM	FORMA	L	A
ISO40L88DCK13	1 ÷ 13	12.000	AD	88	50
ISO40L100DCK16	3 ÷ 16			100	58
ISO50L80DCK13	1 ÷ 13	12.000	AD	80	50
ISO50L90DCK16	3 ÷ 16			90	58

DIN/2080

Porta fresas weldon extra corto DIN 1835-B
Short type end mill holders for DIN 1835-B shanks

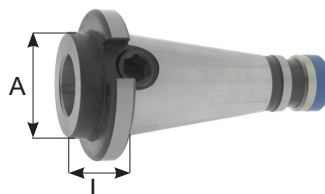
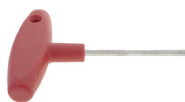

ISO40 / ISO50

REFERENCIA	D	FORMA	L	A
ISO40L22WE16	16	AD	22	44
ISO40L22WE20	20		22	
ISO40L22WE25	25		22	
ISO40L40WE32	32		40	
ISO50L20WE16	16	AD	20	66
ISO50L20WE20	20		20	
ISO50L20WE25	25		20	
ISO50L20WE32	32		20	



DIN/2080

Porta fresas weldon DIN 1835-B
End mill holders for DIN 1835-B

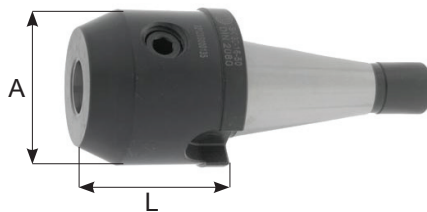
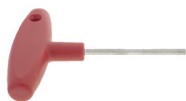

ISO30 / ISO40 / ISO50

REFERENCIA	D	RPM	FORMA	L	A		
ISO30L40WE6	6	12.000	AD	40	25		
ISO30L40WE8	8			40	28		
ISO30L40WE10	10			40	35		
ISO30L40WE12	12			40	42		
ISO30L50WE14	14			50	44		
ISO30L50WE16	16			50	48		
ISO30L50WE18	18			50	50		
ISO30L63WE20	20			63	52		
ISO40L50WE6	6			12.000	AD	50	25
ISO40L50WE8	8					50	28
ISO40L50WE10	10	50	35				
ISO40L50WE12	12	50	42				
ISO40L50WE14	14	50	44				
ISO40L63WE16	16	63	48				
ISO40L63WE18	18	63	50				
ISO40L63WE20	20	63	52				
ISO40L80WE25	25	80	63				
ISO40L80WE32	32	80	72				
ISO40L90WE40	40	90	90				
ISO50L63WE6	6	12.000	AD			63	25
ISO50L63WE8	8			63	28		
ISO50L63WE10	10			63	35		
ISO50L63WE12	12			63	42		
ISO50L63WE14	14			63	44		
ISO50L63WE16	16			63	48		
ISO50L63WE18	18			63	50		
ISO50L63WE20	20			63	52		
ISO50L80WE25	25			80	65		
ISO50L80WE32	32			80	72		
ISO50L90WE40	40			90	90		

Whistle-Notch on request.



DIN/2080

Porta fresas combinado
Combi shell end mill holders

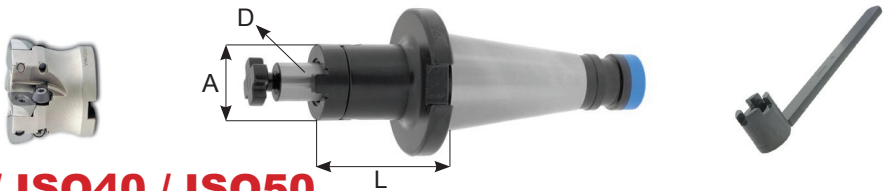

ISO30 / ISO40 / ISO50

REFERENCIA	D	RPM	FORMA	L	A
ISO30L35D16C	16	12.000	AD	35	32
ISO30L35D22C	22			35	40
ISO30L35D27C	27			35	48
ISO30L50D32C	32	12.000	AD	50	58
ISO40L52D16C	16			52	32
ISO40L52D22C	22			52	40
ISO40L52D27C	27			52	48
ISO40L52D32C	32	12.000	AD	52	58
ISO40L52D40C	40			52	70
ISO50L55D16C	16			12.000	AD
ISO50L55D22C	22	55	40		
ISO50L55D27C	27	55	48		
ISO50L55D32C	32	55	58		
ISO50L55D40C	40	55	70		

DIN/2080

Porta fresas fijo
Shell end mill holders



ISO30 / ISO40 / ISO50

REFERENCIA	D	RPM	FORMA	L	A
ISO30L35D16S	16	12.000	AD	35	32
ISO30L35D22S	22			35	40
ISO30L35D27S	27			35	48
ISO30L35D32S	32	12.000	AD	35	58
ISO40L30D16S	16			30	38
ISO40L35D22S	22			35	48
ISO40L35D27S	27			35	58
ISO40L35D32S	32	12.000	AD	35	63
ISO40L35D40S	40			35	79
ISO50L45D16S	16			12.000	AD
ISO50L45D22S	22	45	48		
ISO50L45D27S	27	45	58		
ISO50L45D32S	32	45	65		
ISO50L45D40S	40	45	80		

DIN/2080

Porta fresas fijo gran diámetro
Face mill holders

ISO40 / ISO50

REFERENCIA	D	FORMA	L
ISO40L20D40FM	40	AD	20
ISO40L30D60FM	60	AD	30
ISO50L30D40FM	40	AD	30
ISO50L30D60FM	60	AD	30

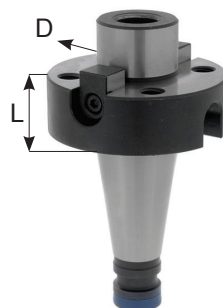

DIN/2080

Mandrino porta brocas
Drill chuck Arbors

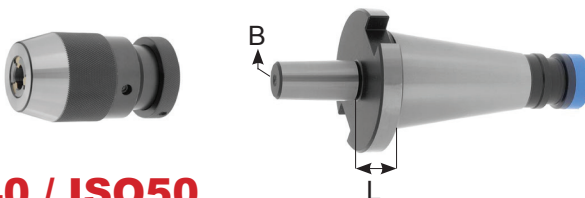

ISO30 / ISO40 / ISO50

REFERENCIA	DIN	B	L
ISO30L15B12	DIN/238	B12	15
ISO30L15B16	DIN/238	B16	15
ISO40L17B12	DIN/238	B12	17
ISO40L17B16	DIN/238	B16	17
ISO40L17B18	DIN/238	B18	17
ISO50L20B16	DIN/238	B16	20
ISO50L20B18	DIN/238	B18	20

DIN/2080

Reductor ISO a ISO DIN/2080
Reducing adaptors ISO a ISO DIN/2080

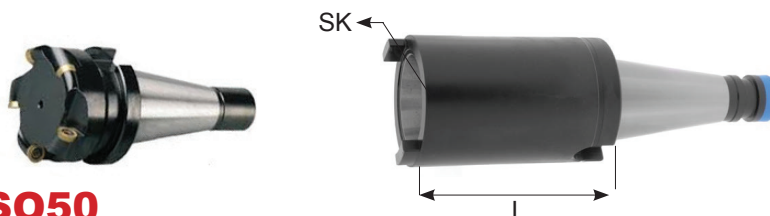

ISO40 / ISO50

REFERENCIA	ISO	FORMA	L	M
ISO40L13ISO30	ISO30	AD	13	M12
ISO40L50ISO30	ISO30		50	M12
ISO40L85ISO40	ISO40		85	M16
ISO50L16ISO30	SK30	AD	16	M12
ISO50L16ISO40	SK40		16	M16
ISO50L60ISO40	SK40		60	M16
ISO50L115ISO50	SK50		115	M24

DIN/2080

Reductor a cono morse DIN/228-A con tornillo tirante
Reducing morse taper shank and drawbar thread DIN/228-A

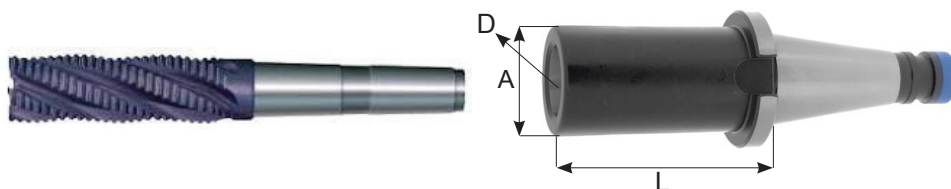

ISO40 / ISO50

REFERENCIA	D	RPM	FORMA	L	A
ISO40L50CM1F	CM1	12.000	AD	50	25
ISO40L50CM2F	CM2			50	32
ISO40L65CM3F	CM3			65	40
ISO40L95CM4F	CM4			95	48
ISO40L110CM4F	CM4			110	63
ISO50L60CM1F	CM1	12.000	AD	60	25
ISO50L60CM2F	CM2			60	32
ISO50L65CM3F	CM3			65	40
ISO50L65CM4F	CM4			65	48
ISO50L80CM4F	CM4			80	63
ISO50L120CM5F	CM5			120	63
ISO50L138CM5F	CM5	138	78		

Reductor a cono morse DIN/228-B
Morse taper adapters DIN/228-B

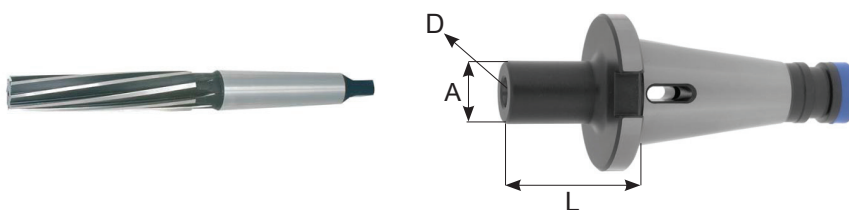

ISO30 / ISO40 / ISO50

REFERENCIA	D	RPM	FORMA	L	A
ISO30L50CM1P	CM1	12.000	AD	50	25
ISO30L50CM2P	CM2			50	32
ISO30L75CM3P	CM3			75	40
ISO40L50CM1P	CM1	12.000	AD	50	25
ISO40L50CM2P	CM2			50	32
ISO40L65CM3P	CM3			65	40
ISO40L95CM4P	CM4			95	48
ISO50L45CM1P	CM1	12.000	AD	45	25
ISO50L60CM2P	CM2			60	32
ISO50L65CM3P	CM3			65	40
ISO50L70CM4P	CM4			70	48
ISO50L105CM5P	CM4			105	63

DIN/2080

Roscador con compresión y tracción DIN/2080
Tension and compression tap holders DIN/2080

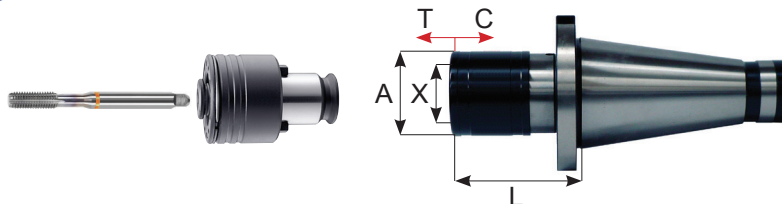

ISO40 / ISO50

REFERENCIA	CAP	X	A	L	C	T
SK40-THTC1-L50	M 3 ÷ M12	19	36	50	7.5	7.5
SK50-THTC1-L59				59		
SK40-THTC2-L78	M 8 ÷ M20	31	53	78	12.5	12.5
SK50-THTC2-L80				80		
SK40-THTC3-L143	M14 ÷ M33	48	78	143	20	20
SK50-THTC3-L130				130		
SK50-THTC4-L152	M22 ÷ M48	60	96	152	22.5	22.5

DIN/2080

Barra mecanizable DIN/2080
Machinable blank Arbors DIN/2080



ISO40 / ISO50

REFERENCIA	D	FORMA	L
ISO40L250D63BL	63	AD	250
ISO50L315D97BL	97	AD	315

