

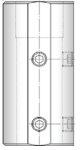

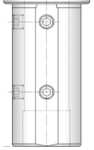

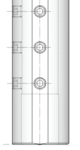

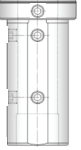

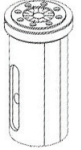



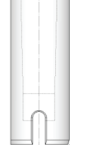



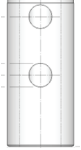

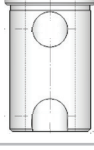
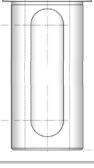
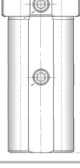
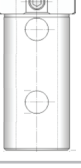
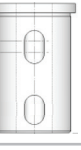

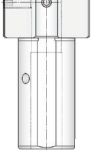
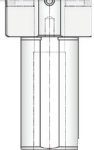







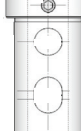

CASQUILLOS

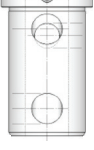
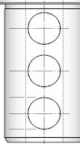
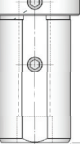
PROGRAMA

						
PAG. 3	PAG. 4	PAG. 5	PAG. 6-7	PAG. 7	PAG. 8	PAG. 9
						
PAG. 10	PAG. 10	PAG. 11	PAG. 11	PAG. 12-14	PAG. 15	PAG. 16
						
PAG. 16	PAG. 17	PAG. 17	PAG. 17	PAG. 18	PAG. 18	PAG. 19
						
PAG. 19	PAG. 19	PAG. 20	PAG. 20	PAG. 20	PAG. 21	PAG. 22
						
PAG. 22	PAG. 23	PAG. 23	PAG. 24	PAG. 24	PAG. 25	PAG. 25
						
PAG. 25	PAG. 26	PAG. 26	PAG. 26	PAG. 27	PAG. 27	PAG. 27

Casquillo universal con tornillo o ventana
Universal Reduction Sleeves or window

FIG. 1

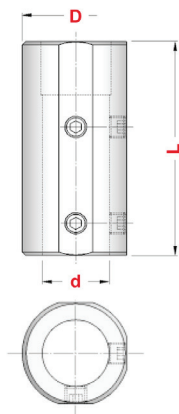

FIG. 2

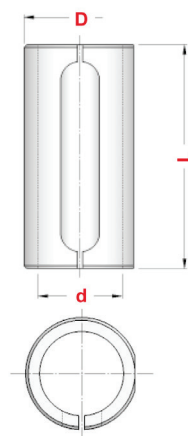
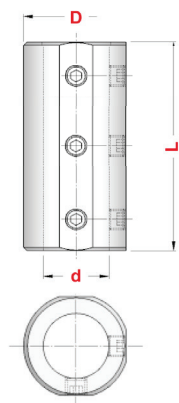
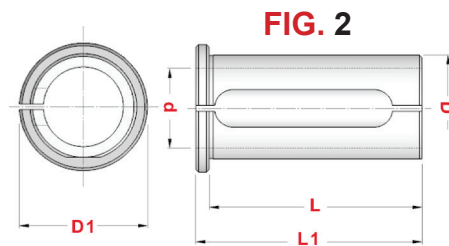
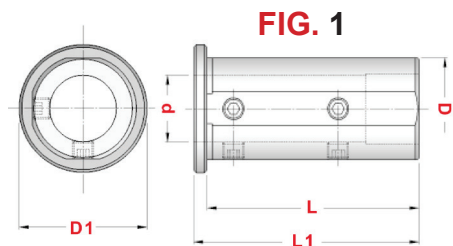

FIG. 3



REFERENCIA	D	d	L	FIG
E21D20x6	20	6	60	1
E21D20x8		8		1
E21D20x10		10		1
E21D20x12		12		1
E21D25x6	25	6	60	1
E21D25x8		8		1
E21D25x10		10		1
E21D25x12		12		1
E21D25x14		14		1
E22D25x16		16		2
E21D32x6	32	6	70	1
E21D32x8		8		1
E21D32x10		10		1
E21D32x12		12		1
E21D32x14		14		1
E21D32x16		16		1
E21D32x18		18		1
E21D32x20		20		1
E22D32x25		25		2
E21D40x6	40	6	80	1
E21D40x8		8		1
E21D40x10		10		1
E21D40x12		12		1
E21D40x14		14		1
E21D40x16		16		1
E21D40x18		18		1
E21D40x20		20		1
E21D40x25		25		1
E22D40x32		32		2
E21D50x12	50	12	90	1
E21D50x14		14		1
E21D50x16		16		1
E21D50x18		18		1
E21D50x20		20		1
E21D50x25		25		1
E21D50x32		32		1
E22D50x40		40		2
E21D60x16	60	16	160	1
E21D60x20		20		1
E21D60x25		25		1
E21D60x32		32		1
E21D60x40		40		1
E21D80x32	80	32	130	3
E21D80x40		40		3
E21D80x50		50		3
E21D80x60		60		3
E21D100x40	100	40	170	3
E21D100x50		50		3
E21D100x60		60		3
E21D100x80		80		3

Casquillo con flangia con tornillo o ventana
Headed Reduction Sleeves or window



REFERENCIA	D	d	L	L1	D	FIG
EG1D20x6	20	6	50	55	28	1
EG1D20x8		8				1
EG1D20x10		10				1
EG1D20x12		12				1
EG2D20x14		14				2
EG1D25x6	25	6	60	65	33	1
EG1D25x8		8				1
EG1D25x10		10				1
EG1D25x12		12				1
EG1D25x14		14				1
EG2D25x16	16	2				
EG2D25x18	18	2				
EG1D32x6	32	6	70	75	40	1
EG1D32x8		8				1
EG1D32x10		10				1
EG1D32x12		12				1
EG1D32x14		14				1
EG1D32x16		16				1
EG1D32x18		18				1
EG1D32x20		20				1
EG2D32x25	25	2				
EG1D40x6	40	6	80	85	48	1
EG1D40x8		8				1
EG1D40x10		10				1
EG1D40x12		12				1
EG1D40x14		14				1
EG1D40x16		16				1
EG1D40x18		18				1
EG1D40x20		20				1
EG1D40x25		25				1
EG2D40x32		32				2
EG1D50x16	50	16	90	95	58	1
EG1D50x18		18				1
EG1D50x20		20				1
EG1D50x25		25				1
EG1D50x32		32				1
EG2D50x40		40				2

Casquillo largo con flangia con tornillo o ventana
 Extended Headed Reductions Sleeves or window

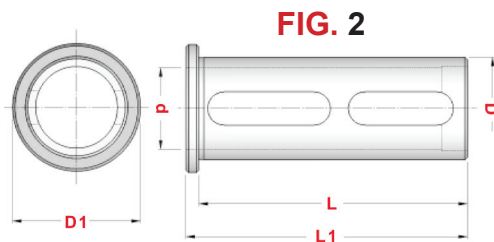
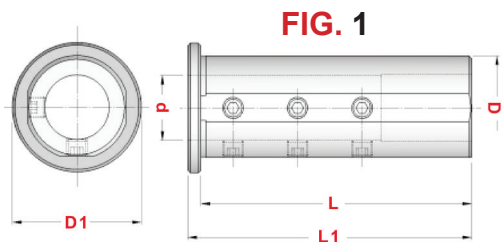

REFERENCIA	D	d	L	L1	D1	FIG
EG3D32x6	32	6	85	90	40	1
EG3D32x8		8				1
EG3D32x10		10				1
EG3D32x12		12				1
EG3D32x14		14				1
EG3D32x16		16				1
EG3D32x18		18				1
EG3D32x20		20				1
EG4D32x25		25				2
EG3D40x6	40	6	105	110	50	1
EG3D40x8		8				1
EG3D40x10		10				1
EG3D40x12		12				1
EG3D40x14		14				1
EG3D40x16		16				1
EG3D40x18		18				1
EG3D40x20		20				1
EG3D40x25		25				1
EG4D40x32	32	2				
EG3D50x12	50	12	125	130	60	1
EG3D50x14		14				1
EG3D50x16		16				1
EG3D50x18		18				1
EG3D50x20		20				1
EG3D50x25		25				1
EG3D50x32		32				1
EG4D50x40	40	2				
EG3D60x20	60	20	135	140	70	1
EG3D60x25		25				1
EG3D60x32		32				1
EG3D60x40		40				1
EG4D60x50		50				2
EG3D80x25	80	25	145	150	90	1
EG3D80x32		32				1
EG3D80x40		40				1
EG3D80x50		50				1
EG4D80x60		60				2

Casquillo con tornillo más flangia con tornillo
Headed Reduction Sleeves plus screw in flange

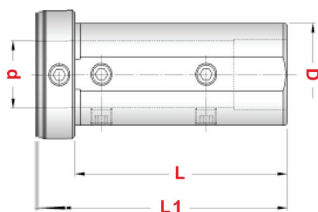

REFERENCIA	D	d	L	L1
ET1D1905x6x50	19.05	6	50	55
ET1D1905x8x50		8		
ET1D1905x10x50		10		
ET1D20x6x50	20	6	50	55
ET1D20x8x50		8		
ET1D20x10x50		10		
ET1D22x6x54	22	6	54	60
ET1D22x8x54		8		
ET1D22x10x54		10		
ET1D25x6x54	25	6	54	60
ET1D25x8x54		8		
ET1D25x10x54		10		
ET1D25x12x54		12		
ET1D254x6x54	25.4	6	54	60
ET1D254x8x54		8		
ET1D254x10x54		10		
ET1D254x12x54		12		
ET1D3175x6x63	31.75	6	63	70
ET1D3175x8x63		8		
ET1D3175x10x63		10		
ET1D3175x12x63		12		
ET1D3175x14x63		14		
ET1D3175x16x63		16		
ET1D3175x20x63	20			
ET1D32x8x40	32	8	40	47
ET1D32x10x40		10		
ET1D32x12x40		12		
ET1D32x16x40		16		
ET1D32x20x40		20		
ET1D32x6x63	32	6	63	70
ET1D32x8x63		8		
ET1D32x10x63		10		
ET1D32x12x63		12		
ET1D32x14x63		14		
ET1D32x16x63		16		
ET1D32x20x63	20			

Casquillo con tornillo más flangia con tornillo
Headed Reduction Sleeves plus screw in flange

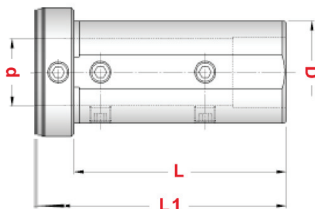

REFERENCIA	D	d	L	L1
ET1D40x6x70	40	6	70	82
ET1D40x8x80		8	80	92
ET1D40x10x80		10		
ET1D40x12x80		12		
ET1D40x14x80		14		
ET1D40x16x80		16		
ET1D40x18x80		18		
ET1D40x20x80		20		
ET1D40x25x80		25		
ET1D50x8x85	50	8		
ET1D50x10x85		10		
ET1D50x12x85		12		
ET1D50x14x85		14		
ET1D50x16x85		16		
ET1D50x20x85		20		
ET1D50x25x85		25		
ET1D50x32x85		32		

Casquillo porta pinzas con tuerca interna y ventana ER DIN/6499
Collet bush holders ER DIN/6499

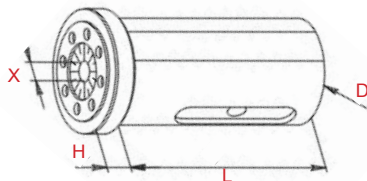

REFERENCIA	D	H	L	X	PINZA
EP2D32ER20	32	5	70	0.5 - 13	ER20
EP2D40ER25	40	5	80	0.5 - 16	ER25

Con paso refrigerante interno
 With inner coolant feeding system

Casquillo con ventana flangia con tornillo
Headed Reduction Sleeves

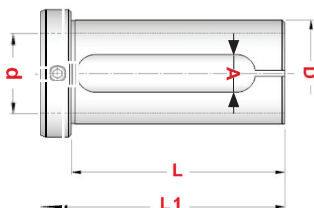

REFERENCIA	D	d	L	L1	A
EV2D20x8x50	20	8	50	58	10.5
EV2D20x10x50		10			
EV2D20x12x50		12			
EV2D20x16x50		16			
EV2D22x12x54	22	12	54	62	11
EV2D22x14x54		14			
EV2D22x16x54		16			
EV2D25x14x55	25	14	55	67	13
EV2D25x16x55		16			
EV2D25x20x55		20			
EV2D254x14x55	25.4	14	55	67	13
EV2D254x16x55		16			
EV2D254x1905x55		19.05			
EV2D254x20x55		20			
EV2D3175x20x65	31.75	20	65	77	13
EV2D3175x25x65		25			
EV2D32x25x40	32	25	40	50	13
EV2D32x20x65	32	20	65	77	13
EV2D32x25x65		25			
EV2D40x16x80	40	16	80	92	14
EV2D40x20x80		20			
EV2D40x25x80		25			
EV2D40x32x89		32			
EV2D50x25x85	50	25	85	97	14
EV2D50x32x85		32			
EV2D50x40x88		40			
EV2D60x32x125	60	32	125	137	14
EV2D60x40x125		40			
EV2D60x50x125		50			

Casquillo de reducción ranurado
Headed Reduction Sleeves with split

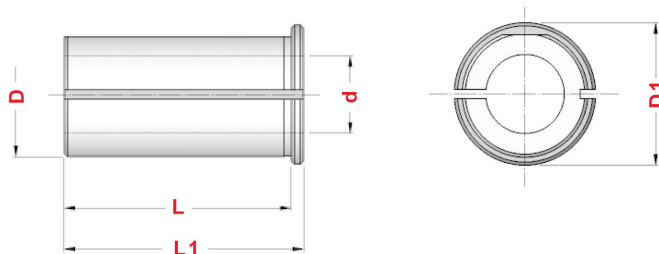

REFERENCIA	D	d	L	L1	D1
RZ20x8	20	8	26	30	25
RZ20x10		10			
RZ20x12		12			
RZ20x14		14			
RZ20x16		16			
RZ25x8	25	8	36	40	30
RZ25x10		10			
RZ25x12		12			
RZ25x14		14			
RZ25x16		16			
RZ25x18		18			
RZ25x20	20				
RZ32x8	32	8	46	50	37
RZ32x10		10			
RZ32x12		12			
RZ32x14		14			
RZ32x16		16			
RZ32x18		18			
RZ32x20		20			
RZ32x25	25				
RZ40x10	40	10	74	78	45
RZ40x12		12			
RZ40x14		14			
RZ40x16		16			
RZ40x18		18			
RZ40x20		20			
RZ40x25		25			
RZ40x32		32			
RZ50x20	50	20	84	88	55
RZ50x25		25			
RZ50x32		32			
RZ50x40		40			
RZ60x25	60	25	88	92	65
RZ60x32		32			
RZ60x40		40			
RZ60x50		50			

Casquillo de reducción con morse
Reduction Sleeves morse taper

FIG. 1

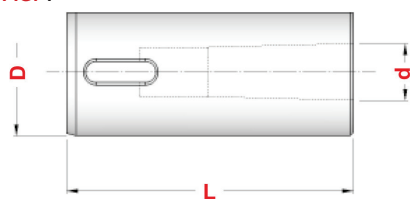

FIG. 2



REFERENCIA	D	CM	d	L	FIG
E23D20x1	20	1	12.065	60	2
E23D20x2		2	17.780	90	1
E23D25x1	25	1	12.065	60	2
E23D25x2		2	17.780	90	1
E23D32x1	32	1	12.065	60	2
E23D32x2		2	17.780	90	1
E23D32x3		3	23.825	100	2
E23D40x2	40	2	17.780	90	1
E23D40x3		3	23.825	100	2
E23D40x4		4	31.267	120	2
E23D50x2	50	2	17.780	90	1
E23D50x3		3	23.825	100	2
E23D50x4		4	31.267	120	2
E23D60x3	60	3	23.825	160	1
E23D60x4		4	31.267	160	1
E23D60x5		5	44.399	160	2



Casquillo de reducción con morse con flangia
Headed reduction sleeves morse taper

FIG. 1

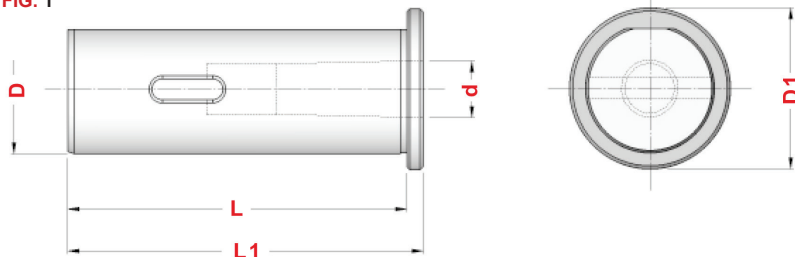
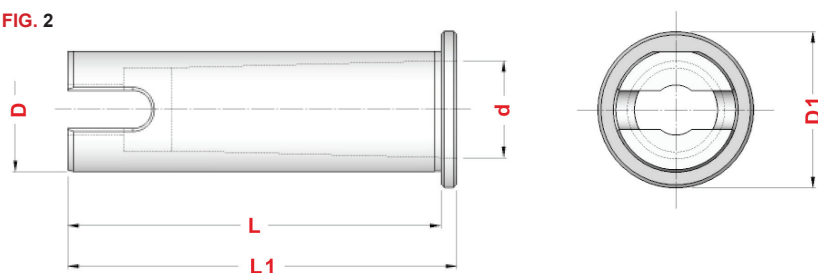

FIG. 2





REFERENCIA	D	CM	d	L	L1	D1	FIG
E2G6D20x1	20	1	12.065	65	70	28	2
E2G6D20x2		2	17.780	70	75		2
E2G6D25x1	25	1	12.065	70	75	33	2
E2G6D25x2		2	17.780	70	75		2
E2G6D25x3		3	23.825	79	98		2
E2G6D32x1	32	1	12.065	85	90	40	1
E2G6D32x2		2	17.780	85	90		1
E2G6D32x3		3	23.825	95	100		2
E2G6D40x2	40	2	17.780	105	110	50	1
E2G6D40x3		3	23.825	105	110		1
E2G6D40x4		4	31.267	120	125		2
E2G6D50x2	50	2	17.780	125	130	63	1
E2G6D50x3		3	23.825	125	130		1
E2G6D50x4		4	31.267	125	130		1
E2G6D60x3	60	3	23.825	130	140	70	1
E2G6D60x4		4	31.267	130	140		1
E2G6D60x5		5	44.399	145	155		2

Casquillo de reducción con flange para porta herramientas E2
con mango VDI20 - 25 - 30

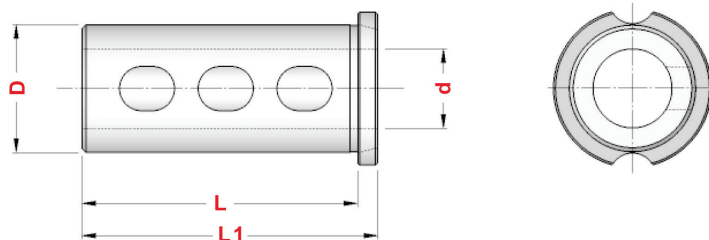
Headed Reduction sleeves for Boring bar holders E2
with shanks VDI20 - 25 - 30



REFERENCIA	D	d	L	L1	(VDI) E2
E2R1D25x8	25	8	47	52	 E2-20x25 E2-25x25 E2-30x25
E2R1D25x10		10			
E2R1D25x12		12			
E2R1D25x14		14			
E2R1D25x16		16			
E2R1D25x18		18			
E2R1D25x20		20			
E2R2D32x8	32	8	57	62	 E2-25x32 E2-30x32
E2R2D32x10		10			
E2R2D32x12		12			
E2R2D32x14		14			
E2R2D32x16		16			
E2R2D32x18		18			
E2R2D32x20		20			
E2R2D32x25	25				
E2R2D40x8	40	8	57	62	 E2-30x40
E2R2D40x10		10			
E2R2D40x12		12			
E2R2D40x14		14			
E2R2D40x16		16			
E2R2D40x18		18			
E2R2D40x20		20			
E2R2D40x25	25				
E2R2D40x32	32				



13

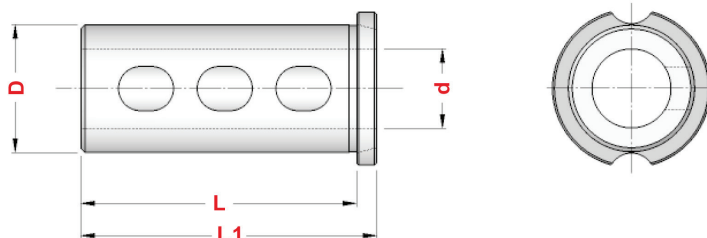

Casquillo de reducción con flange para porta herramientas E2 con mango VDI40

Headed Reduction sleeves for Boring bar holders E2 with shanks VDI40







REFERENCIA	D	d	L	L1	(VDI) E2
E2R2D25x8	25	8	57	62	 E2-40x25
E2R2D25x10		10			
E2R2D25x12		12			
E2R2D25x14		14			
E2R2D25x16		16			
E2R2D25x18		18			
E2R2D25x20		20			
E2R2D32x8	32	8	57	62	 E2-40x32
E2R2D32x10		10			
E2R2D32x12		12			
E2R2D32x14		14			
E2R2D32x16		16			
E2R2D32x18		18			
E2R2D32x20		20			
E2R2D32x25	25				
E2R3D40x8	40	8	70	75	 E2-40x40
E2R3D40x10		10			
E2R3D40x12		12			
E2R3D40x14		14			
E2R3D40x16		16			
E2R3D40x18		18			
E2R3D40x20		20			
E2R3D40x25	25				
E2R3D40x32	32				

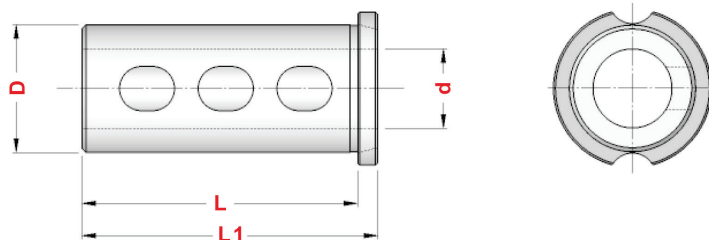

Casquillo de reducción con flange para porta herramientas E2 con mango VDI50 - 60 - 80

Headed Reduction sleeves for Boring bar holders E2 with shanks VDI50 - 60 - 80



REFERENCIA	D	d	L	L1	(VDI) E2
E2R3D25x8	25	8	70	75	 E2-50x25 E2-60x25 E2-80x25
E2R3D25x10		10			
E2R3D25x12		12			
E2R3D25x14		14			
E2R3D25x16		16			
E2R3D25x18		18			
E2R3D25x20		20			
E2R3D32x8	32	8	70	75	 E2-50x32 E2-60x32 E2-80x32
E2R3D32x10		10			
E2R3D32x12		12			
E2R3D32x14		14			
E2R3D32x16		16			
E2R3D32x18		18			
E2R3D32x20		20			
E2R3D32x25	25				
E2R3D40x8	40	8	70	75	 E2-50x40 E2-60x40 E2-80x40
E2R3D40x10		10			
E2R3D40x12		12			
E2R3D40x14		14			
E2R3D40x16		16			
E2R3D40x18		18			
E2R3D40x20		20			
E2R3D40x25	25				
E2R3D40x32	32				

13



Casquillo de reducción para máquina BIGLIA y otros
Short Reduction Sleeves for BIGLIA machines type and others

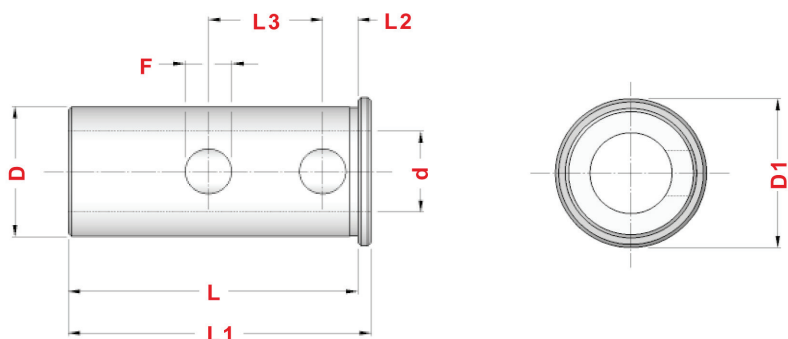

REFERENCIA	D	d	L	L1	L2	L3	F	D1
BG1D25x8	25	8	70	74	7	28	9	32
BG1D25x10		10						
BG1D25x12		12						
BG1D25x14		14						
BG1D25x16		16						
BG1D25x18		18						
BG1D25x20	20							
BG1D32x8	32	8	88	92	9	35	14	36
BG1D32x10		10						
BG1D32x12		12						
BG1D32x14		14						
BG1D32x16		16						
BG1D32x18		18						
BG1D32x20	20							
BG1D32x25	25							
BG1D40x10	40	10	88	92	9	35	14	46
BG1D40x12		12						
BG1D40x14		14						
BG1D40x16		16						
BG1D40x18		18						
BG1D40x20		20						
BG1D40x25	25							
BG1D40x32	32							



Casquillo corto de reducción para máquina BIGLIA y otros
Short Reduction Sleeves for BIGLIA machines type and others

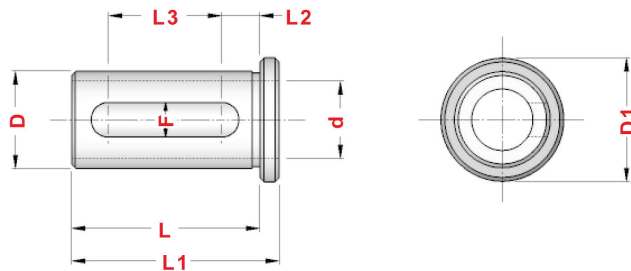

REFERENCIA	D	d	L	L1	L2	L3	F	D1
BG2D25x8	25	8	49	54	10	29.5	9	32
BG2D25x10		10						
BG2D25x12		12						
BG2D25x14		14						
BG2D25x16		16						
BG2D25x18		18						
BG2D25x20		20						

Casquillo corto de reducción para máquina BIGLIA y otros
Short Reduction Sleeves for BIGLIA machines type

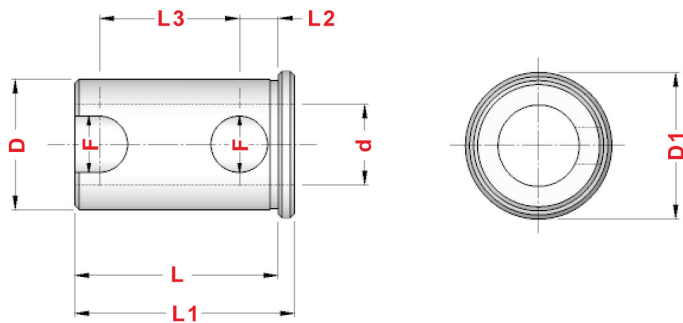

REFERENCIA	D	d	L	L1	L2	L3	F	D1
BG2D32x8	32	8	50	54	9	35	14	36
BG2D32x10		10						
BG2D32x12		12						
BG2D32x14		14						
BG2D32x16		16						
BG2D32x18		18						
BG2D32x20		20						
BG2D32x25	25							

Casquillo de reducción para máquina DAEWOO y otros
Reduction Sleeves for DAEWOO machines type and others

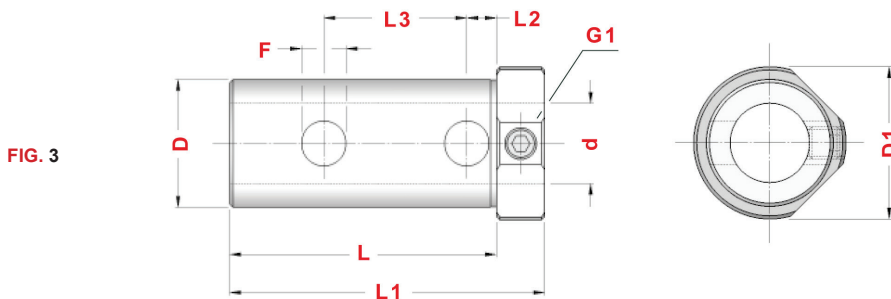
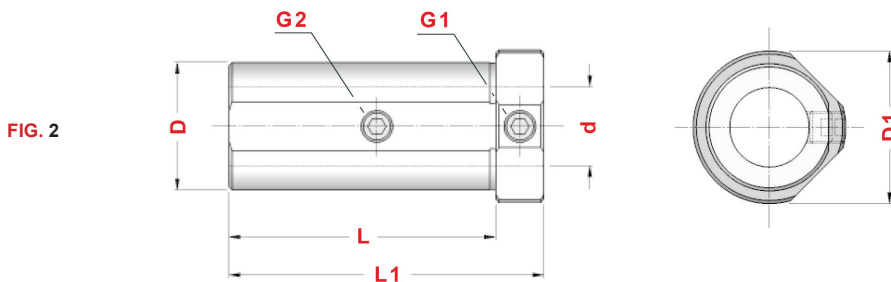
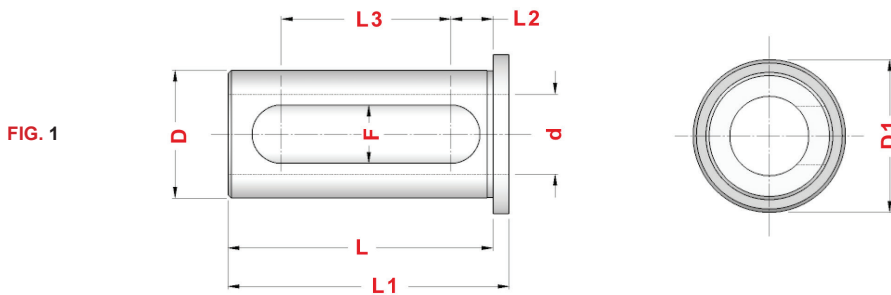

REFERENCIA	D	d	L	L1	L2	L3	F	D1	FIG
DW1D20x8	20	8	44	47	8.5	27	9	25	1
DW1D20x10		10							1
DW1D20x12		12							1
DW1D20x16		16							1
DW1D40x10	40	10	84	99	-	-	-	48	2
DW1D40x12		12			-	-	-		2
DW1D40x16		16			-	-	-		2
DW1D40x20		20			9.5	45	14		3
DW1D40x25		25			9.5	45	14		3
DW1D40x32		32			9.5	45	14		3

Casquillo corto de reducción para máquina DAEWOO y otros
Short Reduction Sleeves for DAEWOO machines type and others

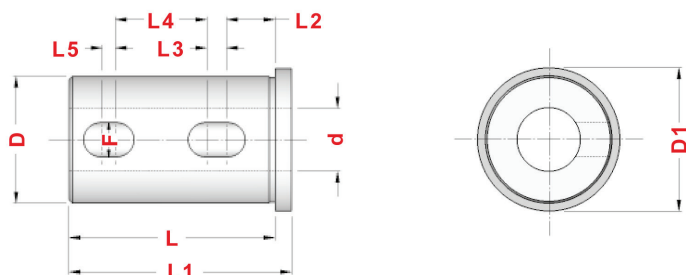

REFERENCIA	D	d	L	L1	L2	L3	L4	L5	F	D1
DW2D40x20	40	20	65	70	15	7	28	5	11	45
DW2D40x25		25								
DW2D40x32		32								

Casquillo de reducción para máquina NAKAMURA TOME y otros
Reduction Sleeves for NAKAMURA TOME machines type and others

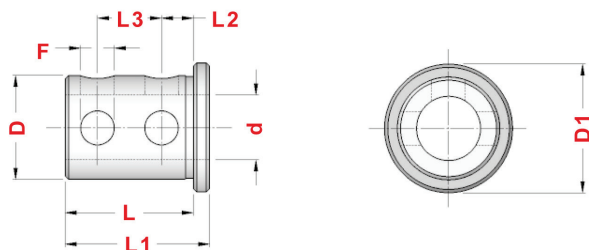

REFERENCIA	D	d	L	L1	L2	L3	F	D1
NT1D25x6	25	6	40	45	10	20	10.5	32
NT1D25x8		8						
NT1D25x10		10						
NT1D25x12		12						
NT1D25x16		16						
NT1D25x20		20						



Casquillo de reducción para máquina MAZAK y otros
Reduction Sleeves for MAZAK machines type and others

FIG. 1

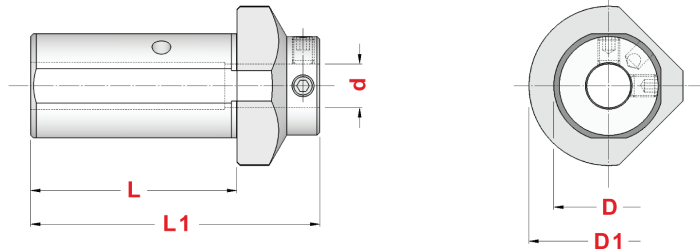

FIG. 2

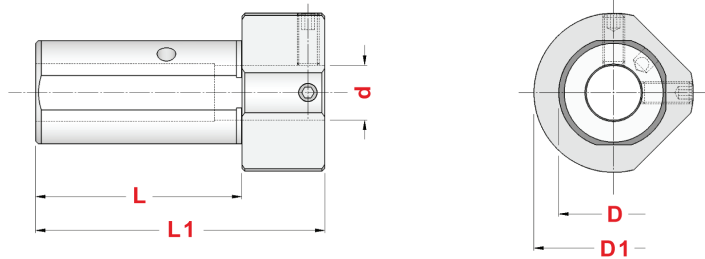
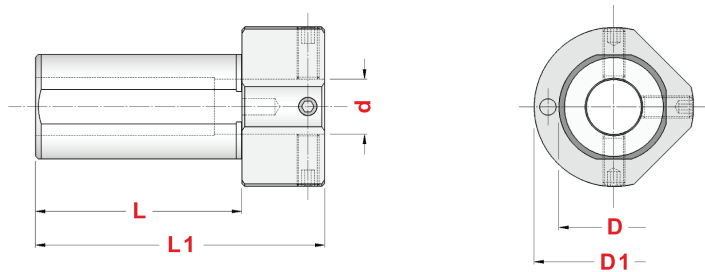
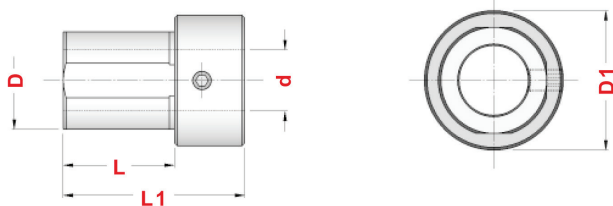

FIG. 3



REFERENCIA	D	d	L	L1	D1	FIG
MZ1D32x8	32	8	60	85	50	1
MZ1D32x10		10				1
MZ1D32x12		12				1
MZ1D32x16		16				1
MZ1D32x20		20				3
MZ1D32x25		25				3
MZ1D40x8	40	8	75	105	58	1
MZ1D40x10		10				1
MZ1D40x12		12				1
MZ1D40x16		16				1
MZ1D40x20		20				2
MZ1D40x25		25				3
MZ1D40x32		32				3

Casquillo corto de reducción para máquina MAZAK y otros
Short Reduction Sleeves for MAZAK machines type and others



REFERENCIA	D	d	L	L1	D1
MZ2D32x20	32	20	40	65	42
MZ2D32x25		25			
MZ2D40x20	40	20	40	65	50
MZ2D40x25		25			
MZ2D40x32		32			

Casquillo de reducción a cono morse para máquina MAZAK y otros
Morse taper Reduction Sleeves for MAZAK machines type and others

FIG. 1

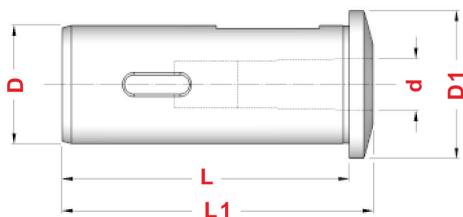
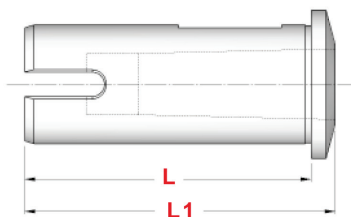

FIG. 2



REFERENCIA	D	CM	d	L	L1	D1	FIG
MZ3D32x1	32	1	12.065	54	66	42	2
MZ3D32x2		2	17.780	58	70		2
MZ3D40x1	40	1	12.065	97	105	50	1
MZ3D40x2		2	17.780	97	105		1
MZ3D40x3		3	23.825	97	105		2



Casquillo de reducción para máquina MORI SEIKI y otros
Reduction Sleeves for MORI SEIKI machines type and others

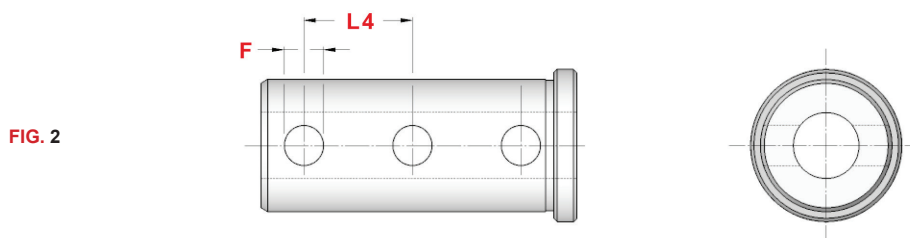
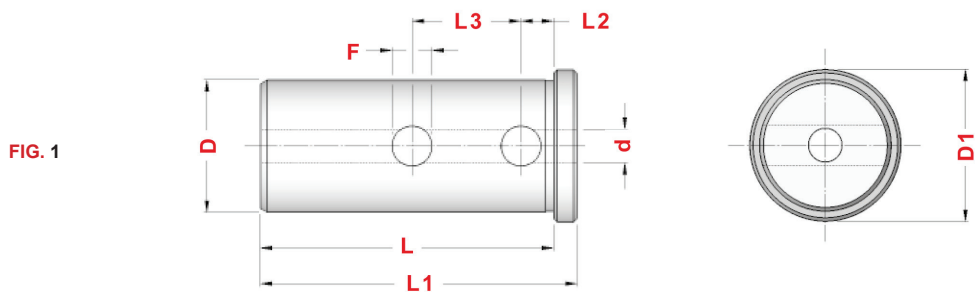

REFERENCIA	D	d	L	L1	L2	L3	L4	F	D1	FIG
MS1D25x8	25	8	78	83	9	31	30	11	30	2
MS1D25x10		10								2
MS1D25x12		12								2
MS1D25x16		16								2
MS1D25x20		20								2
MS1D32x6	32	6	79	86	10	29.5	-	10	38	1
MS1D32x8		8					-			1
MS1D32x10		10					-			1
MS1D32x12		12					29.5			2
MS1D32x16		16					29.5			2
MS1D32x20		20					29.5			2
MS1D32x25		25					29.5			2
MS1D40x8		40					8			89
MS1D40x10	10		-	1						
MS1D40x12	12		-	1						
MS1D40x16	16		33	2						
MS1D40x20	20		33	2						
MS1D40x25	25		33	2						
MS1D40x32	32		33	2						

Casquillo corto de reducción para máquina MORI SEIKI y otros
Short Reduction Sleeves for MORI SEIKI machines type and others

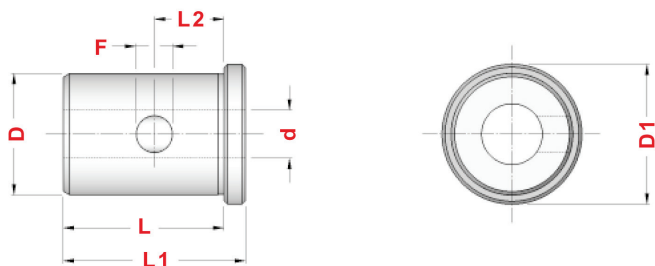

REFERENCIA	D	d	L	L1	L2	L3	F
MS2D32x16	32	16	53	60	20	12	38
MS2D32x20		20					
MS2D32x25		25					
MS2D40x16	40	16	53	60	23	12	46
MS2D40x20		20					
MS2D40x25		25					
MS2D40x32		32					

Casquillo de reducción a cono morse para máquina MORI SEIKI y otros
Morse Taper Reduction Sleeves for MORI SEIKI machines type and others

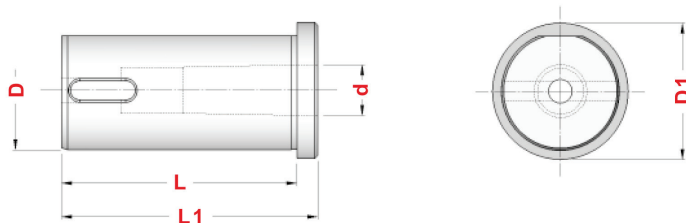

REFERENCIA	D	CM	d	L	L1	D1
MS4D32x1	32	1	12.065	79	86	38
MS4D32x2		2	17.780			
MS4D40x1	40	1	12.065	89	96	46
MS4D40x2		2	17.780			
MS4D40x3		3	23.825			
MS4D40x4		4	31.267			
MS4D50x4	50	4	31.267	89	135	56

Casquillo de reducción con paso refrigerante para máquina
MORI SEIKI y otros
*Through coolant Reduction Sleeves for
MORI SEIKI machines type and others*

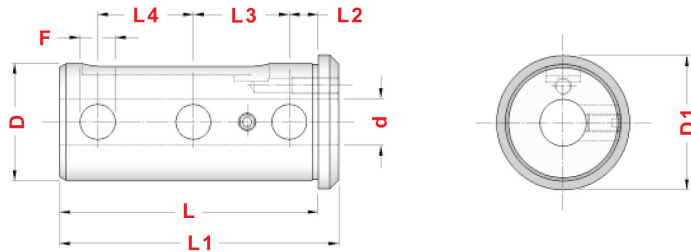

REFERENCIA	D	d	L	L1	L2	L3	L4	F	D1
MS1AD32x8	32	8	78	85	10	29.5	-	10	40
MS1AD32x10		10					-		
MS1AD32x12		12					-		
MS1AD32x16		16					29.5		
MS1AD32x20*		20					29.5		
MS1AD32x25*		25					29.5		
MS1AD40x8	40	8	89	96	10	33	-	12	46
MS1AD40x10		10					-		
MS1AD40x12		12					-		
MS1AD40x16		16					33		
MS1AD40x20		20					33		
MS1AD40x25*		25					33		
MS1AD40x32*	32	33							

* Sin agujero de refrigeración / Without cooling hole

Casquillo corto de reducción con paso refrigerante para máquina
MORI SEIKI y otros
*Through coolant Short Reduction Sleeves for
MORI SEIKI machines type and others*

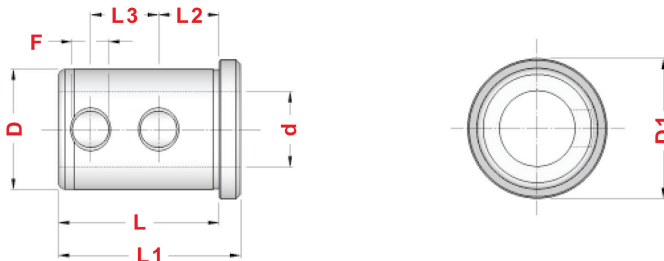

REFERENCIA	D	d	L	L1	L2	L3	F	D1
MS2AD40x16	40	16	53	60	20	22.5	12	46
MS2AD40x20		20						
MS2AD40x25		25						
MS2AD40x32		32						

Casquillo largo de reducción con paso refrigeración para máquina
MORI SEIKI y otros

*Through coolant Extended Reduction Sleeves for MORI SEIKI
machines type and others*

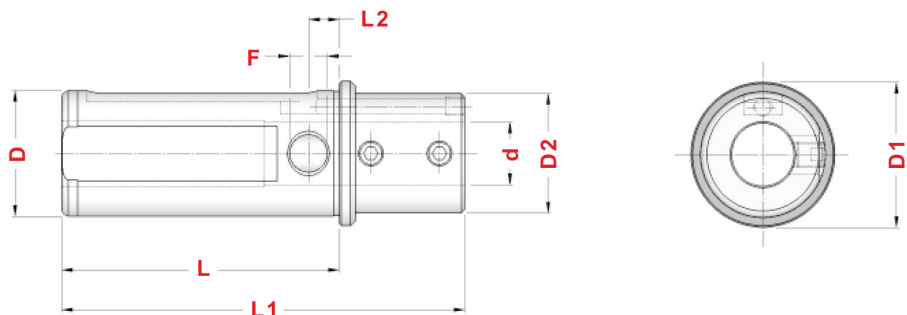

REFERENCIA	D	d	L	L1	L2	F	D1	D2
MS3AD40x8	40	8	89	129	10	12	46	38
MS3AD40x10		10						
MS3AD40x12		12						
MS3AD40x16		16						
MS3AD40x20		20						

Casquillo de reducción a cono morse con paso refrigerante para máquina
MORI SEIKI y otros

*Through coolant Morse Taper Reduction Sleeves for MORI SEIKI
machines type and others*

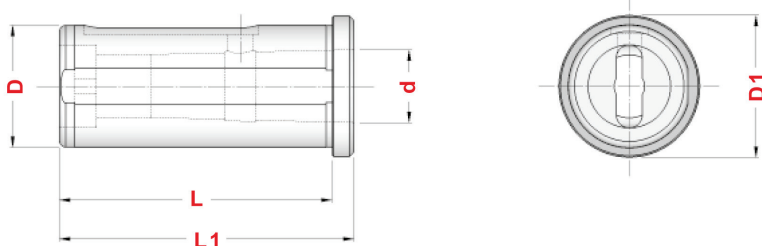

REFERENCIA	D	CM	d	L	L1	D1
MS4AD32x1	32	1	12.065	78	85	40
MS4AD32x2		2	17.780	78	85	40
MS4AD40x1	40	1	12.065	89	96	46
MS4AD40x2		2	17.780	89	96	46
MS4AD40x3		3	23.825	89	96	46
MS4AD40x4		4	31.267	109	116	46

Casquillo de reducción para máquina OKUMA LT 10M / LT 200M y otros
Reduction Sleeves for OKUMA LT 10M / LT200M and others

FIG. 1

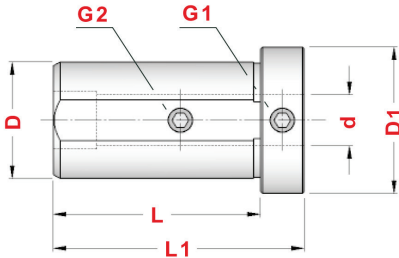
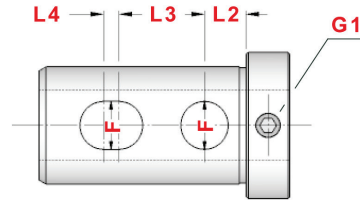

FIG. 2



REFERENCIA	D	d	L	L1	L2	L3	L4	F	D1	FIG
OK1D32x8	32	8	57	69	-	-	-	-	40	1
OK1D32x10		10	57	69	-	-	-	-		1
OK1D32x12		12	57	69	-	-	-	-		1
OK1D32x16		16	59	71	11.5	35	4	13		2
OK1D32x20		20	59	71	11.5	35	4	13		2
OK1D32x25	25	59	71	11.5	35	4	13	2		

Casquillo de reducción para máquina OKUMA LT 15M / LT 300M y otros
Reduction Sleeves for OKUMA LT 15M / LT300M and others

FIG. 1

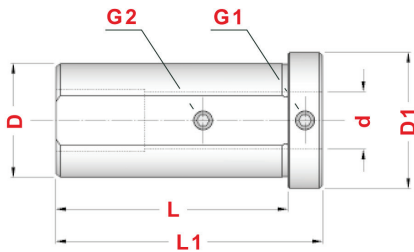
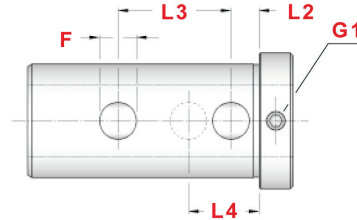

FIG. 2



REFERENCIA	D	d	L	L1	L2	L3	L4	F	D1	FIG
OK2D40x10	40	10	82	94	-	-	-	-	48	1
OK2D40x12		12			-	-	-	-		1
OK2D40x16		16			-	-	-	-		1
OK2D40x20		20			-	-	-	-		1
OK2D40x25		25			10	40	25	13		2
OK2D40x32	32	10	40	25	13	2				

Casquillo de reducción para máquina OKUMA LB 15II / LB 15IIMW y otros
Reduction Sleeves for OKUMA LB 15II / LB 15IIMW machines type and others

FIG. 1

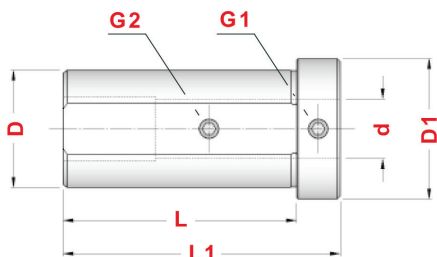
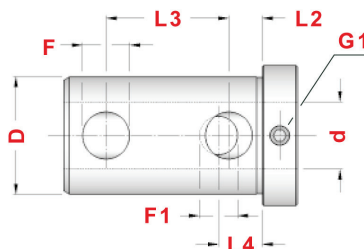

FIG. 2



REFERENCIA	D	d	L	L1	L2	L3	L4	F	F1	D1	FIG
OK4D40x10	40	10	80	95	-	-	-	-	-	48	1
OK4D40x12		12	80	95	-	-	-	-	-		1
OK4D40x16		16	80	95	-	-	-	-	-		1
OK4D40x20		20	80	95	-	-	-	-	-		1
OK4D40x25		25	68	80	11.5	42	15	16	13		2
OK4D40x32		32	68	80	11.5	42	15	16	13		2

Casquillo de reducción para máquina OKUMA LB 15II / LB 15IIMW y otros
Reduction Sleeves for OKUMA LB 15II / LB 15IIMW machines type and others

FIG. 1

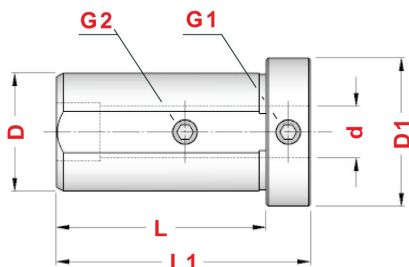
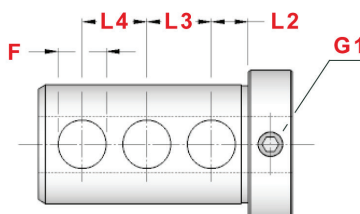

FIG. 2



REFERENCIA	D	d	L	L1	L2	L3	L4	F	D1	FIG	
OK5D40x10	40	10	77	89	-	-	-	-	48	1	
OK5D40x12		12			-	-	-	-		-	1
OK5D40x16		16			-	-	-	-		-	1
OK5D40x20		20			-	-	-	-		-	1
OK5D40x25		25			10	29	29	12		2	
OK5D40x32		32			10	29	29	12		2	

Casquillo de reducción para máquina OKUMA MACTURN 250
MULTUS y otros

Reduction Sleeves for OKUMA MACTURN 250
MULTUS machines type and others

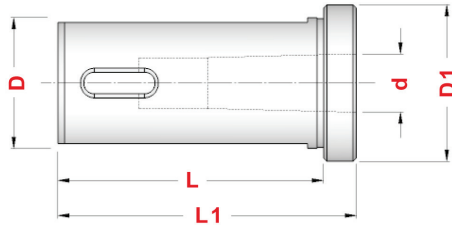

REFERENCIA	D	CM	d	L	L1	D1
OK6D40x1	40	1	12.065	82	87	48
OK6D40x2	40	2	17.780	82	92	48
OK6D40x3	40	3	23.825	82	112	48

Casquillo de reducción a cono morse para máquina OKUMA y otros
Morse Taper Reduction Sleeves for OKUMA machines type and others

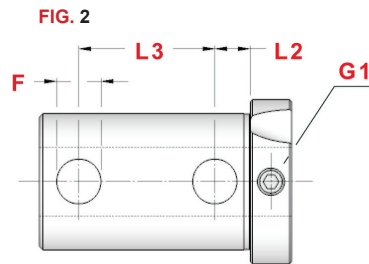
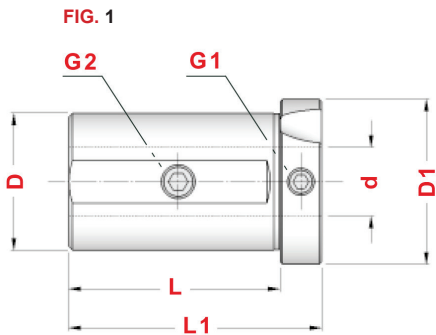

REFERENCIA	D	d	L	L1	L2	L3	L4	F	FIG
OK7D40x10	40	10	62	74	-	-	-	48	1
OK7D40x12		12			-	-	-		1
OK7D40x16		16			-	-	-		1
OK7D40x20		20			-	-	-		1
OK7D40x25		25			11.5	40	13		2
OK7D40x32		32			11.5	40	13		2

